



Cálculo del coeficiente de transmisión térmica (Uf)

Travesaño para Paño fijo y Puerta de Rebartir, con poliamida de 25

Cliente:

Alcemar

Cálculos realizados por

Technoform BAUTEC Ibérica, s.l.

Laia Cardona

Tel: +34 93 238 64 38/ Fax: +34 93 415 40 37

Email: tb-es@technoform.es

Fecha:

19.04.2006

Resultados

Travesaño RPT M-3/25 mediante BISCO según norma EN ISO 10077-2:2003	Uf = 3,22 W/m ² K
Travesaño RPT M-3/25 mediante RADCON con "Know-How" TECHNOFORM	Uf = 3,01 W/m ² K

En este informe se determina el coeficiente de transmisión térmica (Uf) mediante dos métodos de cálculo diferentes:

- A) Aplicando la norma EN ISO 10077-2:2003, y usando el software "BISCO" de la empresa Physibel.
- B) Aplicando un método propio, "know-how" de Technoform, donde se usa el software "RADCON"- también propiedad de Physibel - y el valor final equivale aproximadamente al resultado en el test de cálculo de nuestra HOT-BOX (La diferencia es de un 5%) según norma ISO/FDIS 12567:2000.



Contenido

- Dibujo sistema

A) mediante BISCO según norma EN ISO 10077-2:2003

- Input – data BISCO
- Output – data BISCO
- Cálculo del coeficiente de transmisión térmica (U_f)
- Isotermas
- Flujo de calor

B) mediante RADCON con “Know-How” TECHNOFORM

- Input – data RADCON
- Output – data RADCON
- Cálculo del coeficiente de transmisión térmica (U_f)

Dibujo sistema

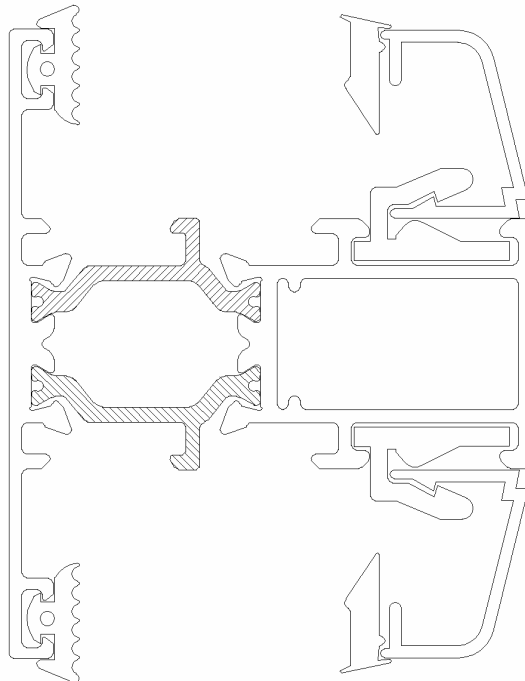



A) mediante BISCO según norma EN ISO 10077-2:2003

Input – data BISCO

Col.	Name	Type	CEN-rule	Coupled	lambda [W/mK]	eps [-]	t [°C]	h [W/m²K]
8	aluminium	MATERIAL			160.000			
28	insulation	MATERIAL			0.040			
44	polyamid reinf.	MATERIAL			0.300			
60	EPDM	MATERIAL			0.250			
119	temp. sensor 1	MATERIAL			160.000			
135	temp. sensor 2	MATERIAL			160.000			
151	temp. sensor 3	MATERIAL			160.000			
170	exterior	BC_SIMPL	HE				0.0	25.00
174	interior (norma	BC_SIMPL	HI_NORML				20.0	7.70
182	interior (reduc	BC_SIMPL	HI_REDUC				20.0	5.00
214	cavity (CEN)	EQUIMAT	CEN_VF_I	NO	0.142			
215	cavity (CEN)	EQUIMAT	CEN_VF_I	NO	0.082			
216	cavity (CEN)	EQUIMAT	CEN_VF_I	NO	0.096			
217	cavity (CEN)	EQUIMAT	CEN_VF_I	NO	0.143			
248	cavity <6x6 mm2	MATERIAL			0.043			
252	cavity <2x2 mm2	MATERIAL			0.031			
253	cavity <1x1 mm2	MATERIAL			0.028			

Col.	q [W/m²]	ta [°C]	hc [W/m²K]	qc [W/m]	tr [°C]	C1 [-]	C2 [-]	C3 [-]
8								
28								
44								
60								
119								
135								
151								
170	0							
174	0							
182	0							
214						0.025	0.73	0.333333
215						0.025	0.73	0.333333
216						0.025	0.73	0.333333
217						0.025	0.73	0.333333
248								
252								
253								

Calculation parameters

Contour approximation margin (triangulation) = 0 pixels
 Iteration cycles = 5
 Recalculation of CEN values (before each iteration cycle)
 Maximum number of iterations (per iteration cycle) = 10000
 Maximum temperature difference = 0.0001°C
 Max. heat flow divergence for total object = 0.001 %
 Max. heat flow divergence for any node = 1 %



Output – data BISCO

Col.	Name	Type	tmin [°C]	tmax [°C]	ta [°C]	flow in [W/m]	flow out [W/m]
8	aluminium	MATERIAL	1.85	14.61			
28	insulation	MATERIAL	0.91	17.01			
44	polyamid reinf.	MATERIAL	1.91	14.36			
60	EPDM	MATERIAL	1.39	15.01			
119	temp. sensor 1	MATERIAL	15.65	15.65			
135	temp. sensor 2	MATERIAL	14.53	14.53			
151	temp. sensor 3	MATERIAL	15.57	15.57			
170	exterior	BC_SIMPL	0.91	1.90		0.00	8.29
174	interior (norma	BC_SIMPL	14.52	17.01		6.87	0.00
182	interior (reduc	BC_SIMPL	14.60	16.42		1.42	0.00
214	cavity (CEN)	EQUIMAT	1.87	14.89			
215	cavity (CEN)	EQUIMAT	1.91	14.36			
216	cavity (CEN)	EQUIMAT	14.36	14.53			
217	cavity (CEN)	EQUIMAT	1.87	14.93			
248	cavity <6x6 mm2	MATERIAL	14.41	14.55			
252	cavity <2x2 mm2	MATERIAL	1.85	14.54			
253	cavity <1x1 mm2	MATERIAL	1.62	14.72			



Cálculo del coeficiente de transmisión térmica (Uf)

THERMAL TRANSMITTANCE ACCORDING TO prEN 10077-2

Theory

The thermal transmittance of a frame according to PrEN 10077-2:

$$U_f = \frac{L_{2D} - U_p * l_p}{l_f} \quad \text{and} \quad L_{2D} = \frac{q_{l,tot}}{\Delta \theta}$$

- with:
- U_f : thermal transmittance of the window frame [W/m²K]
 - U_p : thermal transmittance of the flanking panel [W/m²K]
 - l_p : projected width of the flanking panel [m]
 - l_f : projected width of the window frame [m]
 - L_{2D} : two-dimensional coupling coefficient [W/mK]
 - $q_{l,tot}$: total heat flow through the window frame and the flanking panel [W/m]
 - $\Delta \theta$: temperature difference between inside (θ_i) and outside (θ_e) [K]

Calculation	Item:		
input data:	$q_{l,tot} =$	7,970 W/m	$R_{se} =$ 0,04 m ² K/W
	$\theta_e =$	0,0 °C	$R_{si} =$ 0,13 m ² K/W
	$\theta_i =$	20,0 °C	
	$d_i =$	0,0280 m	
	$\lambda_i =$	0,035 W/m*K	
	$U_p =$	1,031 W/m ² K	
	$l_p =$	0,190 m	
	calculation results:		$L_{2D} =$ 0,41 W/mK
	$l_f =$	0,0680 m	$U_f =$ 3,22 W/m ² K

input data using the Physibel Software BISCO

- $q_{l,tot}$: alphanumeric output BISCO
- heat losses per boundary condition
- $\Delta \theta$: input data, surface boundary conditions:
inside temperature minus outside temperature
- U_p : calculation, using the following formula:

$$U_p = \left[\frac{1}{h_e} + \sum \frac{d_i}{\lambda_i} + \frac{1}{h_i} \right]^{-1}$$

- with: h_e / h_i ext./int. surface heat transfer coeff. [W/m²K]
- d_i thickness of layer i [m]
- λ_i thermal conductivity of layer i [W/mK]

- l_p / l_f : input data: dimensions of the item

PHYSIBEL Heirweg 21 B-9990 Maldegem Belgium tel +32 50 711432 fax +32 50 717842



Isotermas

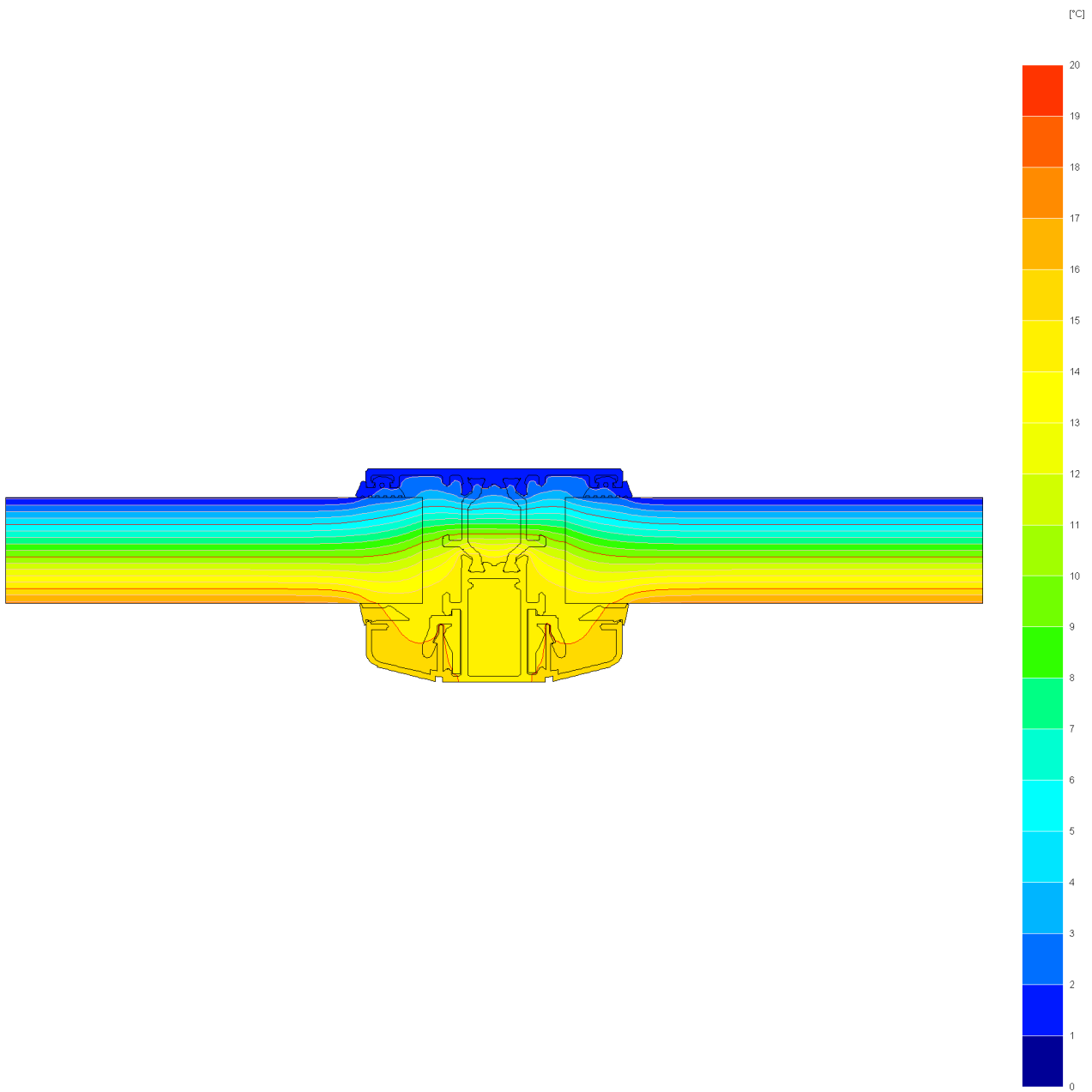



Flujo de calor

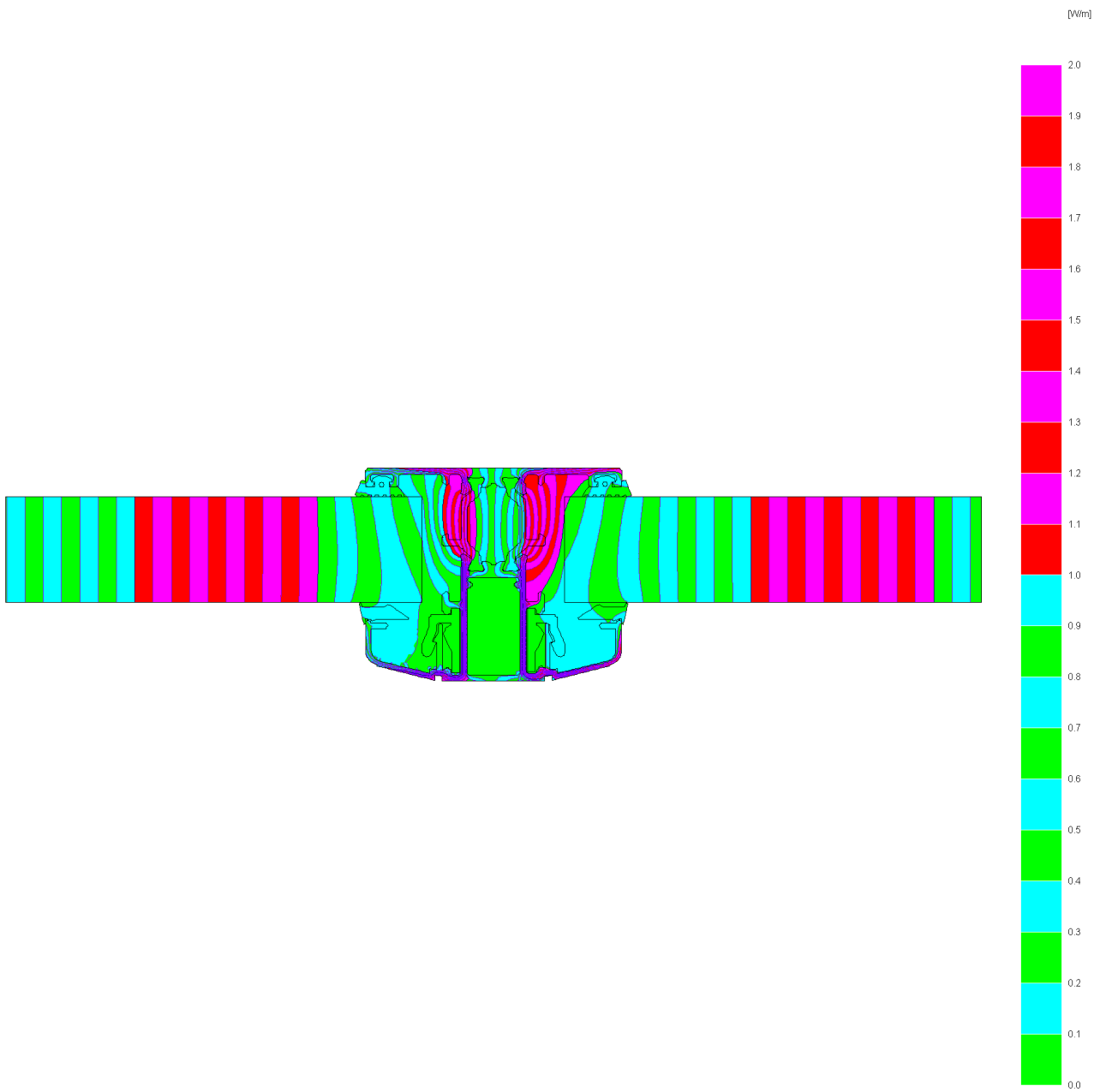



B) mediante RADCON con “Know-How” TECHNOFORM

Input – data RADCON

Col.	Name	Type	CEN-rule	Coupled	lambda [W/mK]	eps [-]	t [°C]	h [W/m²K]
8	aluminium	MATERIAL			160.000	0.90		
28	insulation	MATERIAL			0.035	0.90		
44	polyamid reinf.	MATERIAL			0.300	0.90		
60	EPDM	MATERIAL			0.250	0.90		
119	temp. sensor 1	MATERIAL			160.000	0.90		
135	temp. sensor 2	MATERIAL			160.000	0.90		
151	temp. sensor 3	MATERIAL			160.000	0.90		
156	insulation far	MATERIAL			0.035	0.90		
170	exterior	BC_SKY	NIHIL					
174	interior 1	BC_SKY	NIHIL					
182	interior 2	BC_SKY	NIHIL					
190	interior 3	BC_SKY	NIHIL					
214	cavity	BC_FREE	CEN_VF_I	NO				
215	cavity	BC_FREE	CEN_VF_I	NO				
216	cavity	BC_FREE	CEN_VF_I	NO				
217	cavity	BC_FREE	CEN_VF_I	NO				
248	cavity <6x6 mm2	MATERIAL			0.043	0.90		
252	cavity <2x2 mm2	MATERIAL			0.031	0.90		
253	cavity <1x1 mm2	MATERIAL			0.028	0.90		

Col.	q [W/m²]	ta [°C]	hc [W/m²K]	qc [W/m]	tr [°C]	C1 [-]	C2 [-]	C3 [-]
8								
28								
44								
60								
119								
135								
151								
156								
170	0	0.0	12.00		0.0			
174	0	20.0	2.33		20.0			
182	0	20.0	2.58		20.0			
190	0	20.0	2.71		20.0			
214	0		2.62	0		0.0248	0.58	0.333333
215	0		2.63	0		0.0248	0.58	0.333333
216	0		1.98	0		0.0253	0.58	0.25
217	0		2.62	0		0.0248	0.58	0.333333
248								
252								
253								

Calculation parameters

Contour approximation margin (triangulation) = 0 pixels

Iteration cycles = 5

Nonlinear radiation

Recalculation of CEN values (before each iteration cycle)

Smallest accepted viewfactor = 0.001

Number of visibility rays between radiative surfaces = 100

Black radiation heat transfer coeff. (linear radiation) = 5.25 W/m²K



Maximum number of iterations (per iteration cycle) = 10000
 Maximum temperature difference = 0.0001°C
 Max. heat flow divergence for total object = 0.001 %
 Max. heat flow divergence for any node = 1 %

Output – data RADCON

Col.	Name	Type	tmin [°C]	tmax [°C]	ta [°C]	flow in [W/m]	flow out [W/m]
8	aluminium	MATERIAL	3.03	14.52			
28	insulation	MATERIAL	1.27	16.77			
44	polyamid reinf.	MATERIAL	3.08	14.37			
60	EPDM	MATERIAL	2.43	14.68			
119	temp. sensor 1	MATERIAL	16.02	16.02			
135	temp. sensor 2	MATERIAL	14.47	14.47			
151	temp. sensor 3	MATERIAL	15.80	15.80			
156	insulation far	MATERIAL	1.23	17.27			
170	exterior	BC_SKY	1.23	3.08		0.00	7.93
174	interior 1	BC_SKY	16.77	17.27		3.24	0.00
182	interior 2	BC_SKY	14.52	16.77		1.66	0.00
190	interior 3	BC_SKY	14.47	14.52		3.02	0.00
214	cavity	BC_FREE	3.05	14.60	11.19	1.53	1.53
215	cavity	BC_FREE	3.08	14.37	8.82	0.74	0.74
216	cavity	BC_FREE	14.37	14.48	14.42	0.01	0.01
217	cavity	BC_FREE	3.05	14.60	11.18	1.54	1.54
248	cavity <6x6 mm2	MATERIAL	14.30	14.49			
252	cavity <2x2 mm2	MATERIAL	3.03	14.47			
253	cavity <1x1 mm2	MATERIAL	2.65	14.57			



Cálculo del coeficiente de transmisión térmica (Uf)

THERMAL TRANSMITTANCE ACCORDING TO prEN 10077-2

Theory

The thermal transmittance of a frame according to PrEN 10077-2:

$$U_f = \frac{L_{2D} - U_p * l_p}{l_f} \quad \text{and} \quad L_{2D} = \frac{q_{l,tot}}{\Delta \theta}$$

- with:
- U_f : thermal transmittance of the window frame [W/m²K]
 - U_p : thermal transmittance of the flanking panel [W/m²K]
 - l_p : projected width of the flanking panel [m]
 - l_f : projected width of the window frame [m]
 - L_{2D} : two-dimensional coupling coefficient [W/mK]
 - $q_{l,tot}$: total heat flow through the window frame and the flanking panel [W/m]
 - $\Delta \theta$: temperature difference between inside (θ_i) and outside (θ_e) [K]

Calculation	Item:		
input data:	$q_{l,tot} = 7,930$ W/m	$R_{se} = 0,06$ m ² K/W	
	$\theta_e = 0,0$ °C	$R_{si} = 0,13$ m ² K/W	
	$\theta_i = 20,0$ °C		
	$d_i = 0,0280$ m		
	$\lambda_i = 0,035$ W/m*K		
	$U_p = 1,010$ W/m ² K		
	$l_p = 0,190$ m		
	calculation results:	$L_{2D} = 0,40$ W/mK	
	$l_f = 0,0680$ m	$U_f = 3,01$ W/m ² K	

input data using the Physibel Software BISCO

- $q_{l,tot}$: alphanumeric output BSKO
heat losses per boundary condition
- $\Delta \theta$: input data, surface boundary conditions:
inside temperature minus outside temperature
- U_p : calculation, using the following formula:

$$U_p = \left[\frac{1}{h_e} + \sum \frac{d_i}{\lambda_i} + \frac{1}{h_i} \right]^{-1}$$

- with: h_e / h_i ext./int. surface heat transfer coeff. [W/m²K]
- d_i thickness of layer i [m]
- λ_i thermal conductivity of layer i [W/mK]

- l_p / l_f : input data: dimensions of the item

PHYSIBEL Heirweg 21 B-9990 Maldegem Belgium tel +32 50 711432 fax +32 50 717842